

PowerTech™ 6090AFM85 Diesel Engine

Marine Propulsion Engine Specifications

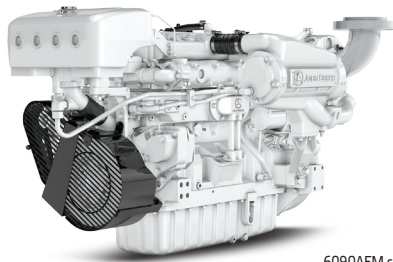

6090AFM shown

Dimensions

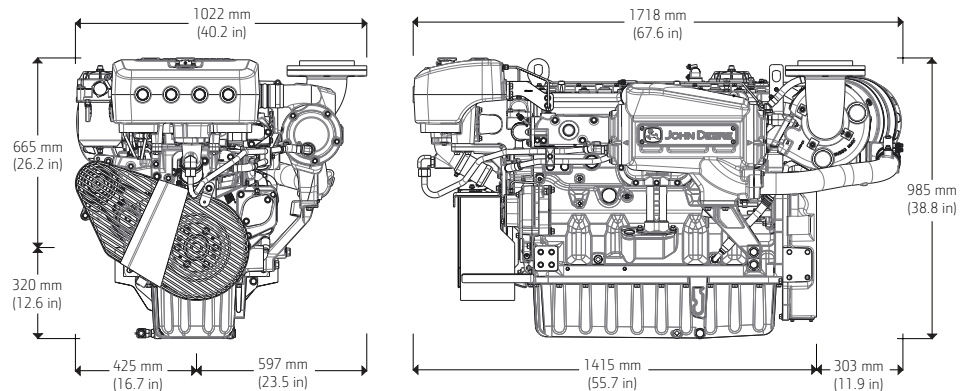

Dimensions shown in mm (in) may vary according to options selected.
Contact your distributor for more information.

Emissions

EPA Commercial Marine Tier 3
IMO MARPOL Annex VI Compliant
NRMM (97/68/EC) as amended

General Data (based on standard option configuration)

Model	6090AFM85
Number of cylinders	6
Displacement – L(cu in)	9.0 (549)
Bore and Stroke – mm (in)	118 x 136 (4.65 x 5.35)
Engine Type	In-line, 4-cycle
Aspiration	Turbocharged and air-to-coolant aftercooled

Length maximum – mm (in)	1718 (67.6)
Length to rear face of flywheel housing – mm (in)	1415 (55.7)
Flywheel housing SAE	SAE #2
Width maximum – mm (in)	1022 (40.2)
Crankshaft centerline right – mm (in)	597 (23.5)
Crankshaft centerline left – mm (in)	425 (16.7)
Height – mm (in)	985 (38.8)
Height, crankshaft centerline to top – mm (in)	665 (26.2)
Height, crankshaft centerline to bottom – mm (in)	320 (12.6)
Weight, dry – kg (lb)	1055 (2325)

Classification Societies

SOLAS – Accessories available*
ABS, DNV, BV, LR

*Other accessories available. Contact your distributor for details.

Engine Specifications

Performance ratings	Power kW (bhp)	Rated Speed (rpm)	Rated fuel consumption L/hr (gal/hr)
M1	213 (285)	2100	64.6 (17.1)
M2	243 (325)	2200	71.5 (18.9)
M3	280 (375)	2300	80.9 (21.4)
M4	317 (425)	2400	91.2 (24.1)

Metric hp = Brake hp x 1.01387

M rating	M1	M2	M3	M4
Typical load factor	>65%	≤65%	≤50%	≤40%
Typical Annual Usage (hr)	Unrestricted	3,000-5,000	2,000-4,000	1,000-3,000
Typical full-power operation (hr)	Uninterrupted	16 of each 24 hr	4 of each 12 hr	1 of each 12 hr

Ratings are based on ISO 8655 standard power rating and the SAE J1228 crankshaft power rating.

For easier installation, JDPS offers a range of options to fit your needs.

See your John Deere Power Systems engine distributor or marine dealer for more detailed performance information.

Features and Benefits

High torque and low rated RPM

- High torque provides excellent vessel control and maneuverability
- Lower rated propulsion RPM reduces vibration and noise for improved crew comfort

High-pressure common-rail (HPCR)

- The HPCR fuel system provides variable common-rail pressure, multiple injections, and higher injection pressures
- Controls fuel injection timing and provides precise control for the start, duration, and end of injection
- Transfer pump with priming option
- Provides high performance, excellent fuel economy, and low emissions

Keel-cooled or heat exchanger

- Closed cooling system in keel-cooled engine option eliminates the need for a sea strainer, seawater pump, or anodes
- Heat exchanger option offers a lighter, more compact, and simpler installation for the vessel

Multiple service options

- Either-side oil fill/dipstick combinations and remote oil filter options are available for easier service access

4-valve cylinder head

- Excellent airflow through 4-valve cylinder head delivers greater low-speed torque and better transient response time

Water-cooled exhaust manifold

- Integrated components eliminate external hoses and fittings
- Wet exhaust manifold creates a cooler and quieter environment for passengers and crew

Replaceable cylinder liners

- Replaceable wet-type cylinder liners are precision-machined and hardened for long life
- Allows engine to be rebuilt to original specifications

Electronic engine control unit (ECU)

- Advanced fault code diagnostics and customizable engine protections ensure reliability and uptime
- Provides highly customizable features and trim to integrate your vessel

John Deere Power Systems
3801 W. Ridgeway Ave.
PO Box 5100
Waterloo, IA 50704-5100
Phone: 800.553.6446
Fax: 319.292.5075

John Deere Power Systems
Usine de Saran
La Foulonnerie B.P. 11.13
45401 Fleury les Aubrais Cedex
France
Phone: 33.2.38.82.61.19
Fax: 33.2.38.82.60.00

All values at rated speed and power with standard options unless otherwise noted. Specifications and design subject to change without notice.