

PowerTech™ EWX 4045TFC03 Diesel Engine

Industrial Engine Specifications

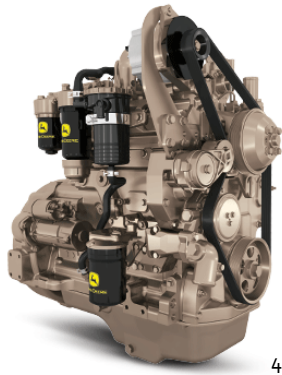

4045TFC03 shown

Certifications

CARB
EPA Tier 4
EU Stage III B

Engine dimensions

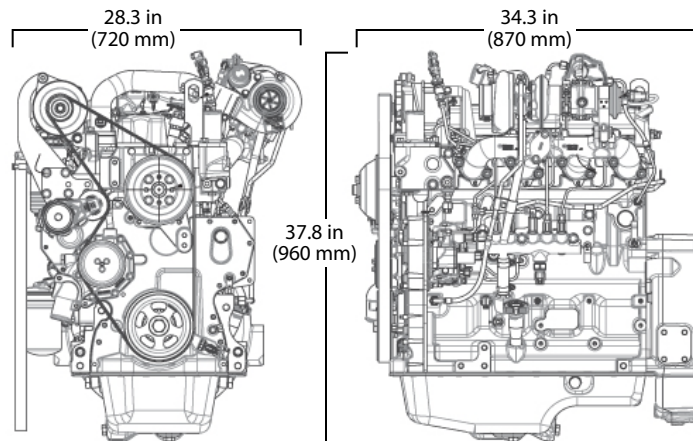

Dimensions may vary according to options selected. Call your distributor for more information.

General data

Model	4045TFC03	Length – mm (in)	870 (34.3)
Number of cylinders	4	Width – mm (in)	720 (28.3)
Displacement – L (cu in)	4.5 (275)	Height – mm (in)	960 (37.8)
Bore and stroke – mm (in)	106 x 127 (4.2 x 5.0)	Weight, dry – kg (lb)	~ 500 (1100)
Engine type	In-line, 4-cycle		
Aspiration	Turbocharged		

Performance data range

Application ratings	Continuous
Rated power/Rated speed	55 kW (74 hp) @ 2200 – 2400 rpm
Peak power	55 kW (74 hp) @ 2200 – 2400 rpm
Power bulge	0%
Peak torque	304 N.m (224 ft-lb) @ 1600 rpm
Torque rise	up to 39%

The Industrial Intermittent engine power rating is for applications that operate at varying loads and speeds, and do not fit the Industrial Heavy-Duty rating definition.

Some applications require Industrial Heavy-Duty engine power ratings. Please contact your John Deere Power Systems engine distributor for more information.

The Industrial Continuous engine power rating is for applications that operate with constant load and speed, except for short periods during startup or shutdown.

Power output is within + or – 5% at standard SAE J 1995 and ISO 3046.

Exhaust filter dimensions

Size	2
Diameter – mm (in)	260.71 (10.26)
Length – mm (in)	572.59 (22.54)
Weight – kg (lb)	19.96 (44)

See your John Deere Power Systems engine distributor for more information on available filter size options.

Features and benefits

Wastegated turbocharger

- Wastegated turbochargers are designed to develop more airflow at lower engine speeds to improve low-speed torque. The wastegate control device bleeds off a portion of the exhaust flow at higher engine speeds.
- Wastegated turbos deliver improved transient response and higher peak torque without compromising engine envelope size. They also provide the lowest installed cost across a given power range.

Exhaust filters

- These engines utilize a catalyzed exhaust filter that contains a diesel oxidation catalyst (DOC) and a diesel particulate filter (DPF). The DOC reacts with exhaust gases to reduce carbon monoxide, hydrocarbons, and some particulate matter (PM). The downstream DPF traps and holds the remaining PM. Trapped particles are oxidized within the DPF through a continuous cleaning process called passive regeneration.
- Passive regeneration occurs during normal operating conditions when heat from the exhaust stream and catalysts within the exhaust filter trigger the oxidation of the trapped PM. If passive regeneration cannot be achieved due to low temperature, load, or speed, then PM is removed using active regeneration — an automatic cleaning process controlled by the exhaust temperature management system.

High-pressure common-rail (HPCR) and engine control unit (ECU)

- The HPCR fuel system provides variable common-rail pressure, multiple injections, and higher injection pressures up to 1,975 bar (29,000 psi). It also controls fuel injection timing and provides precise control for the start, duration, and end of injection.

2-valve cylinder head

- Cross-flow head design provides excellent breathing from a lower-cost 2-valve cylinder head.

Turbocharged

- In turbocharged engines, the air is precompressed. Due to the higher pressure, more air is supplied into the combustion chamber, allowing a corresponding increase in fuel injection, which results in greater engine output.

Air-to-air aftercooled

- This is the most efficient method of cooling intake air to help reduce engine emissions while maintaining low-speed torque, transient response time, and peak torque.

Compact size

- Lower installed cost.
- Mounting points are the same as previous engine models.

John Deere electronic engine controls

- Engine control unit (ECU) manages both the engine and the aftertreatment system.
- Premium software option integrates with equipment or vehicles to reduce engineering and installation costs.

John Deere Power Systems
3801 W. Ridgeway Ave.
PO Box 5100
Waterloo, IA 50704-5100
Phone: 800.553.6446
Fax: 319.292.5075

John Deere Power Systems
Usine de Saran
La Foulonnerie - B.P. 11.13
45401 Fleury les Aubrais Cedex
France
Phone: 33.2.38.82.61.19
Fax: 33.2.38.82.60.00

All values at rated speed and power with standard options unless otherwise noted. Specifications and design subject to change without notice.

