

PowerTech™ PSS 4045HFC09 Diesel Engine

Industrial Engine Specifications

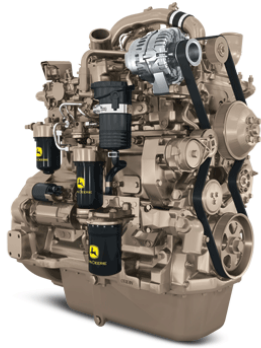

4045HFC09 shown

Engine dimensions

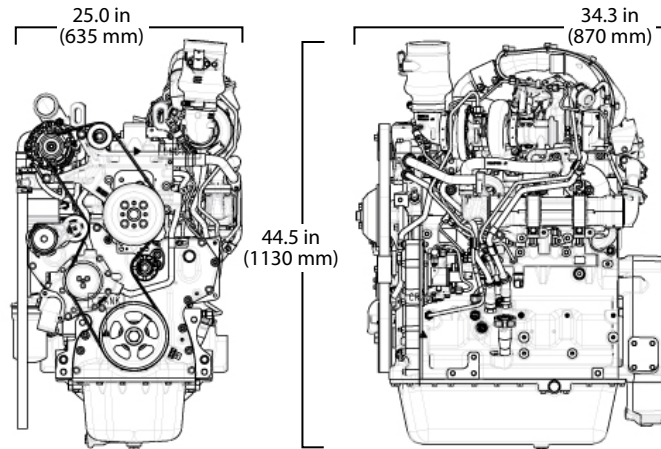

Dimensions may vary according to options selected. Call your distributor for more information.

CARB
EPA Tier 4
EU Stage IV

General data

Model	4045HFC09	Length – mm (in)	870 (34.3)
Number of cylinders	4	Width – mm (in)	635 (25.0)
Displacement – L (cu in)	4.5 (275)	Height – mm (in)	1130 (44.5)
Bore and stroke – mm (in)	106 x 127 (4.2 x 5.0)	Weight, dry – kg (lb)	~ 567 (1250)
Engine type	In-line, 4-cycle		
Aspiration	Turbocharged and air-to-air aftercooled		

Performance data range

Application ratings	Intermittent	Heavy Duty	Continuous
Rated power/Rated speed	116–129 kW (155–175 hp) @ 2200–2400 rpm	104–106 kW (140–155 hp) @ 2200–2400 rpm	93–104 kW (125–140 hp) @ 2200–2400 rpm
Peak power	116–129 kW (155–175 hp) @ 2200–2400 rpm	112–116 kW (150–155 hp) @ 2200–2400 rpm	93–104 kW (125–140 hp) @ 2200–2400 rpm
Power bulge	0–8% @ 2000 rpm	0–8% @ 2000 rpm	0–8% @ 2000 rpm
Peak torque	616–667 N.m (455–492 ft-lb) @1600 rpm	552–667 N.m (407–492 ft-lb) @1600 rpm	494–601 N.m (365–443 ft-lb) @1600 rpm
Torque rise	19-33%	33%	33%

The Industrial Intermittent engine power rating is for applications that operate at varying loads and speeds, and do not fit the Industrial Heavy-Duty rating definition.

Some applications require Industrial Heavy-Duty engine power ratings. Please contact your John Deere Power Systems engine distributor for more information.

Exhaust filter dimensions

Size	3	4
Diameter – mm (in)	320.04 (12.6)	320.04 (12.6)
Length – mm (in)	578.85 (22.8)	635 (25)
Weight – kg (lb)	33.57 (62)	30.84 (68)

See your John Deere Power Systems engine distributor for more information on available filter size options.

The Industrial Continuous engine power rating is for applications that operate with constant load and speed, except for short periods during startup or shutdown.

Power output is within + or – 5% at standard SAE J 1995 and ISO 3046.

SCR catalyst dimensions

Size	3	4
Diameter – mm (in)	322.58 (12.7)	322.58 (12.7)
Length – mm (in)	673.1 (26.5)	774.7 (30.5)
Weight – kg (lb)	34.02 (75)	39.01 (86)

Features and benefits

Series turbochargers

- Fresh air is first drawn into the low-pressure turbocharger (fixed geometry) and compressed to a higher pressure. The compressed air is then drawn into the high-pressure turbocharger (VGT or WGT), where the air is further compressed. The high-pressure air is then routed through a charge air cooler and into the engine's intake manifold.
- By splitting the work between two turbochargers, both can operate at peak efficiency and at slower rotating speeds — lowering stress on turbocharger components and improving reliability. Series turbocharging delivers more boost pressure than single turbocharger configurations, which results in higher power density, improved low-speed torque, and improved high-altitude operation.

Cooled exhaust gas recirculation (EGR)

- EGR cools and mixes measured amounts of cooled exhaust gas with incoming fresh air to lower peak combustion temperatures, thereby reducing NOx.

Exhaust filters

- These engines utilize a catalyzed exhaust filter that contains a diesel oxidation catalyst (DOC) and a diesel particulate filter (DPF). The DOC reacts with exhaust gases to reduce carbon monoxide, hydrocarbons, and some particulate matter (PM).
- The downstream DPF traps and holds the remaining PM. Trapped particles are oxidized within the DPF through a continuous cleaning process called passive regeneration. Passive regeneration occurs during normal operating conditions when heat from the exhaust stream and catalysts within the exhaust filter trigger the oxidation of the trapped PM. If passive regeneration cannot be achieved due to low temperature, load, or speed, then PM is removed using active regeneration — an automatic cleaning process controlled by the exhaust temperature management system.

Selective catalytic reduction (SCR)

- John Deere engines feature an SCR system that utilizes a urea-based additive, sometimes referred to as diesel exhaust fluid (DEF). The ammonia in the urea mixes with engine exhaust gases in the SCR catalyst to reduce NOx — converting it to nitrogen and water vapor.

High-pressure common-rail (HPCR) and engine control unit (ECU)

- The HPCR fuel system provides variable common-rail pressure, multiple injections, and higher injection pressures up to 2,500 bar (36,000 psi). It also controls fuel injection timing and provides precise control for the start, duration, and end of injection.

4-valve cylinder head

- The 4-valve cylinder head provides excellent airflow resulting in greater low-speed torque and better transient response time by utilizing a cross-flow design.

Air-to-air aftercooled

- This is the most efficient method of cooling intake air to help reduce engine emissions while maintaining low-speed torque, transient response time, and peak torque. It enables an engine to meet emissions regulations with better fuel economy and the lowest installed costs.

Compact size

- Lower installed cost.
- Mounting points are the same as previous engine models.

Engine performance

- Multiple rated speeds to further reduce noise and improve fuel economy.
- Peak torque equal to or better than Interim Tier 4/Stage III B; peak torque equal to or better than Interim Tier 4/Stage III B; transient response time equal to Interim Tier 4/Stage III B; low-speed torque similar to Interim Tier 4/Stage III B; optional power bulge equal to or better than Interim Tier 4/Stage III B.

John Deere electronic engine controls

- Faster engine control unit (ECU) manages both the engine and the aftertreatment system; four times the memory, twice the RAM and double the processing speed; the input/output capability has increased 40%; premium software option integrates with equipment or vehicles to reduce engineering and installation costs.

Additional features*

- Glow plugs; gear-driven auxiliary drives; 500-hour oil change; self-adjusting poly-vee fan drive; optional factory installed variable-speed fan drive improves fuel economy and reduces noise levels; R.H. and L.H. engine-mounted fuel filters; low-pressure fuel system with electrical transfer pump and “auto-prime” feature.

* Available on all PowerTech PSS engines unless noted.

John Deere Power Systems
3801 W. Ridgeway Ave.
PO Box 5100
Waterloo, IA 50704-5100
Phone: 800.553.6446
Fax: 319.292.5075

John Deere Power Systems
Usine de Saran
La Foulonnerie - B.P. 11.13
45401 Fleury les Aubrais Cedex
France
Phone: 33.2.38.82.61.19
Fax: 33.2.38.82.60.00

All values at rated speed and power with standard options unless otherwise noted. Specifications and design subject to change without notice.

Litho in U.S.A. (14-01) © 2014 JOHN DEERE

